

Write your name here

Surname	Other names
---------	-------------

**Pearson Edexcel Certificate** Centre Number 

--	--	--	--	--

 Candidate Number 

--	--	--	--

**Pearson Edexcel International GCSE**

# Chemistry

**Unit: KCH0/4CH0**  
**Science (Double Award) KSC0/4SC0**  
**Paper: 1C**

Monday 18 January 2016 – Afternoon <b>Time: 2 hours</b>	Paper Reference <b>KCH0/1C 4CH0/1C</b> <b>KSC0/1C 4SC0/1C</b>
--	---

<b>You must have:</b> Ruler, calculator	Total Marks
--	-------------

### Instructions

- Use **black** ink or ball-point pen.
- **Fill in the boxes** at the top of this page with your name, centre number and candidate number.
- Answer **all** questions.
- Answer the questions in the spaces provided  
– *there may be more space than you need.*
- Show all the steps in any calculations and state the units.
- Some questions must be answered with a cross in a box ☒. If you change your mind about an answer, put a line through the box ☒ and then mark your new answer with a cross ☒.

### Information

- The total mark for this paper is 120.
- The marks for **each** question are shown in brackets  
– *use this as a guide as to how much time to spend on each question.*

### Advice

- Read each question carefully before you start to answer it.
- Write your answers neatly and in good English.
- Try to answer every question.
- Check your answers if you have time at the end.

Turn over ►

P46814A

©2016 Pearson Education Ltd.

1/1/1/1/1/1/1/1/



**PEARSON**

THE PERIODIC TABLE

Period	Group 1		Group 2												Group 7		0
1	1 H Hydrogen 1																4 He Helium 2
2	7 Li Lithium 3	9 Be Beryllium 4											19 F Fluorine 9	20 Ne Neon 10			
3	23 Na Sodium 11	24 Mg Magnesium 12											35.5 Cl Chlorine 17	40 Ar Argon 18			
4	39 K Potassium 19	40 Ca Calcium 20	45 Sc Scandium 21	46 Ti Titanium 22	51 V Vanadium 23	52 Cr Chromium 24	55 Mn Manganese 25	56 Fe Iron 26	59 Co Cobalt 27	59 Ni Nickel 28	63.5 Cu Copper 29	65 Zn Zinc 30	73 Ga Gallium 31	75 As Arsenic 33	79 Se Selenium 34	80 Br Bromine 35	84 Kr Krypton 36
5	86 Rb Rubidium 37	88 Sr Strontium 38	89 Y Yttrium 39	91 Zr Zirconium 40	93 Nb Niobium 41	96 Mo Molybdenum 42	99 Tc Technetium 43	101 Ru Ruthenium 44	103 Rh Rhodium 45	106 Pd Palladium 46	108 Ag Silver 47	112 Cd Cadmium 48	115 In Indium 49	122 Sb Antimony 51	128 Te Tellurium 52	127 I Iodine 53	131 Xe Xenon 54
6	133 Cs Caesium 55	137 Ba Barium 56	139 La Lanthanum 57	179 Hf Hafnium 72	181 Ta Tantalum 73	184 W Tungsten 74	186 Re Rhenium 75	190 Os Osmium 76	192 Ir Iridium 77	195 Pt Platinum 78	197 Au Gold 79	201 Hg Mercury 80	204 Tl Thallium 81	209 Bi Bismuth 83	210 Po Polonium 84	210 At Astatine 85	222 Rn Radon 86
7	223 Fr Francium 87	226 Ra Radium 88	227 Ac Actinium 89														

Key

Relative atomic mass
Symbol
Name
Atomic number

DO NOT WRITE IN THIS AREA

DO NOT WRITE IN THIS AREA

DO NOT WRITE IN THIS AREA

DO NOT WRITE IN THIS AREA

DO NOT WRITE IN THIS AREA

DO NOT WRITE IN THIS AREA



DO NOT WRITE IN THIS AREA

DO NOT WRITE IN THIS AREA

DO NOT WRITE IN THIS AREA

DO NOT WRITE IN THIS AREA

DO NOT WRITE IN THIS AREA

DO NOT WRITE IN THIS AREA

**BLANK PAGE**



**Answer ALL questions.**

**1** Use the the Periodic Table on page 2 to answer this question.

(a) (i) The symbol for silver is

(1)

- A** Ag     **B** As     **C** S     **D** Si

(ii) The element with an atomic number of 40 is

(1)

- A** Al     **B** Ar     **C** Ca     **D** Zr

(b) An atom of an element has the electronic configuration 2.8.3

(i) State the number of the group in the Periodic Table in which this element is found.

(1)

(ii) Explain your answer in terms of the atom's electronic configuration.

(1)

(iii) State the number of the period in the Periodic Table in which this element is found.

(1)

(iv) Explain your answer in terms of the atom's electronic configuration.

(1)

(v) Identify the element.

(1)

DO NOT WRITE IN THIS AREA

DO NOT WRITE IN THIS AREA

DO NOT WRITE IN THIS AREA

DO NOT WRITE IN THIS AREA

DO NOT WRITE IN THIS AREA

DO NOT WRITE IN THIS AREA



(c) Complete the diagram to show the electronic configuration of an atom of fluorine, using x to represent an electron.

(1)

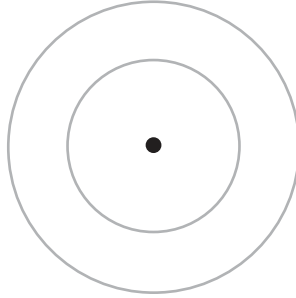

(Total for Question 1 = 8 marks)



2 Bromine is an element in Group 7 of the Periodic Table.

(a) What is the name given to the Group 7 elements?

(1)

- A alkali metals     B alkaline earth metals     C halogens     D noble gases

(b) The symbols of two isotopes of bromine are  ${}^{79}_{35}\text{Br}$  and  ${}^{81}_{35}\text{Br}$ .

(i) State what is meant by the term **isotopes**.

(2)

.....

.....

.....

(ii) Complete the table to show the number of protons, neutrons and electrons in one atom of  ${}^{79}_{35}\text{Br}$  and in one atom of  ${}^{81}_{35}\text{Br}$ .

(3)

Isotope	Number of protons	Number of neutrons	Number of electrons
${}^{79}_{35}\text{Br}$			
${}^{81}_{35}\text{Br}$			

DO NOT WRITE IN THIS AREA

DO NOT WRITE IN THIS AREA

DO NOT WRITE IN THIS AREA

DO NOT WRITE IN THIS AREA

DO NOT WRITE IN THIS AREA

DO NOT WRITE IN THIS AREA



(c) Bromine water can be used to distinguish between ethane and ethene.

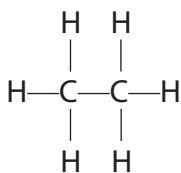

ethane

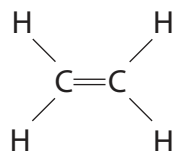

ethene

Describe what you would observe when orange bromine water is added separately to ethane and ethene, in the absence of UV light.

(2)

observation with ethane.....

observation with ethene.....

**(Total for Question 2 = 8 marks)**





- 3 The table shows the percentage composition of the mixture of gases in the exhaust fumes of a car.

Name of gas	Percentage of the gas in the exhaust fumes
carbon dioxide	14.0
carbon monoxide	2.0
hydrocarbons	0.3
nitrogen oxides	0.2
sulfur dioxide	trace amounts
water vapour	12.0
gas Z	71.5

- (a) Identify gas Z.

(1)

- (b) The carbon dioxide is produced from the combustion of hydrocarbons such as octane. Complete the word equation for the complete combustion of octane.

(1)

octane + ..... → carbon dioxide + .....

- (c) How is the carbon monoxide in the exhaust fumes produced?

(1)

- (d) (i) Write a chemical equation to show how nitrogen dioxide ( $\text{NO}_2$ ) is produced in a car engine.

(1)

- (ii) State one problem caused by nitrogen dioxide in the atmosphere.

(1)

(Total for Question 3 = 5 marks)





4 A sample of air is passed through the apparatus shown in the diagram.

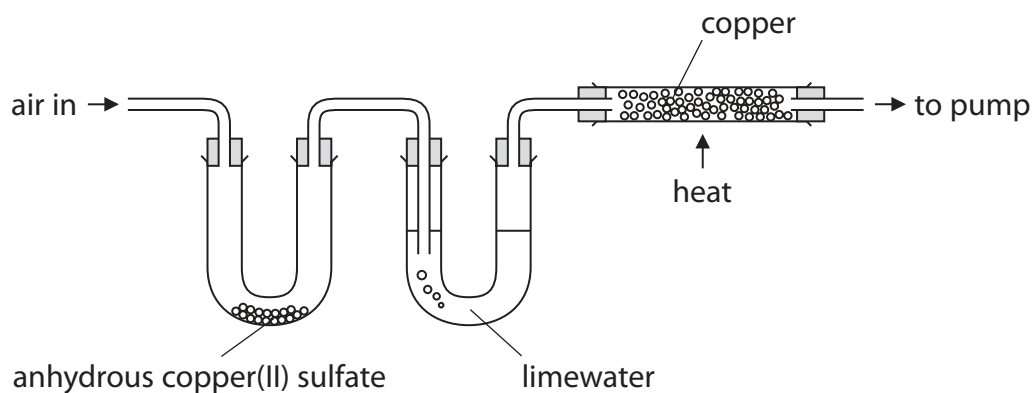

The anhydrous copper(II) sulfate turns from white to blue.

The limewater turns milky.

The copper turns black.

(a) Name the substance that turns anhydrous copper(II) sulfate blue.

(1)

(b) Name the substance that reacts with limewater to make it turn milky.

(1)

(c) Explain why the copper turns black.

(2)

(Total for Question 4 = 4 marks)



P 4 6 8 1 4 A 0 9 3 2

- 5 A student carries out an investigation into the reaction between magnesium carbonate and dilute sulfuric acid. He uses this apparatus.

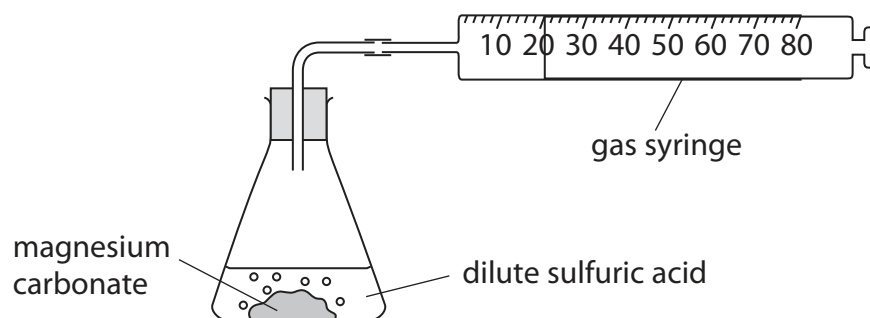

The student carries out seven experiments. In each experiment he uses the same mass of magnesium carbonate but a different volume of acid. He measures the total volume of carbon dioxide collected in each experiment. The table shows his results.

Volume of sulfuric acid used in $\text{cm}^3$	0	5	15	20	25	30	35	40
Volume of carbon dioxide collected in $\text{cm}^3$	0	16	47	61	64	78	80	80

- (a) Plot the results on the grid and draw a curve of best fit.

(3)

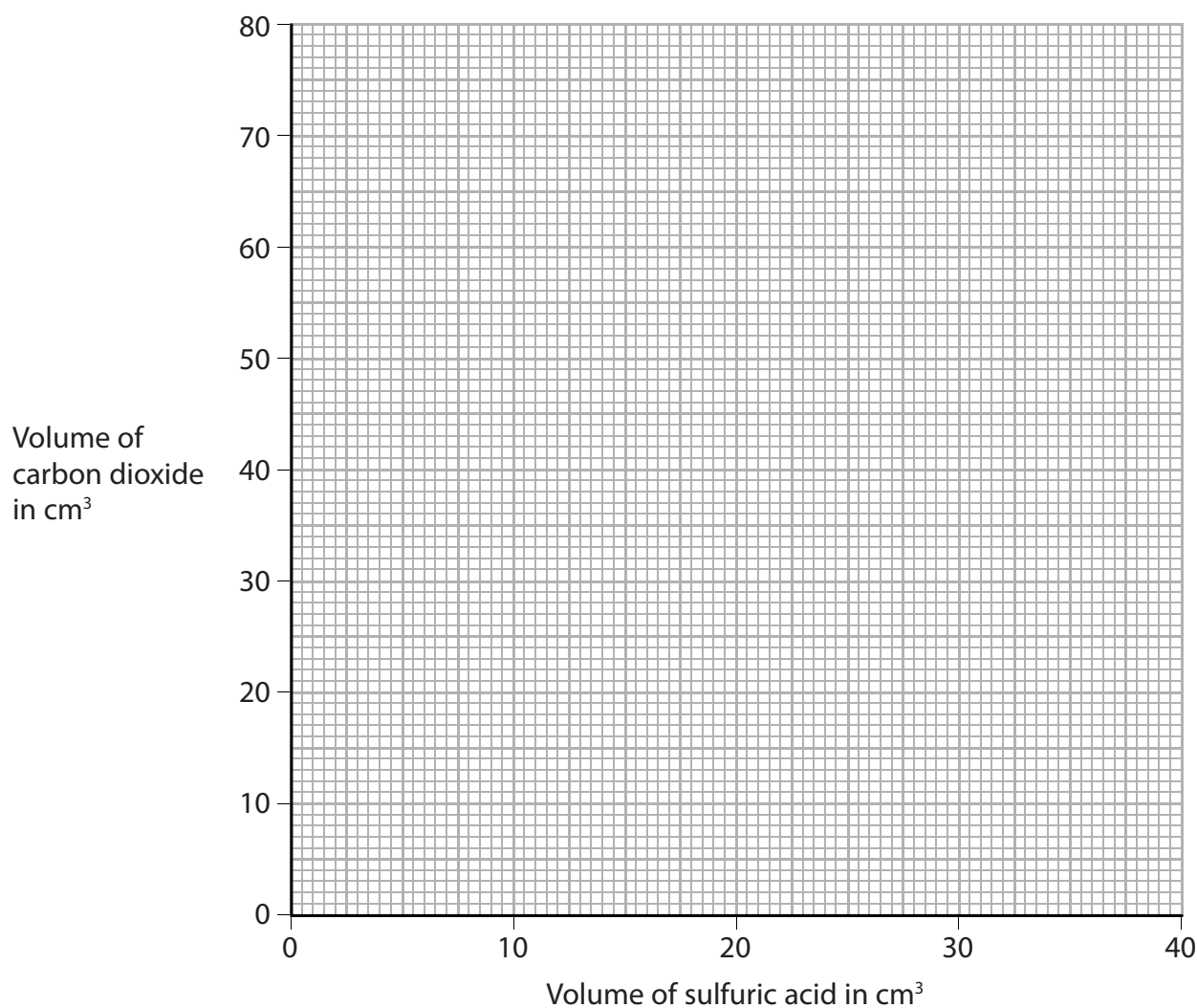

(b) (i) Which volume of sulfuric acid produces an anomalous result? (1)

.....

(ii) Explain what the results with 35 cm<sup>3</sup> and 40 cm<sup>3</sup> of sulfuric acid indicate about the reaction. (2)

.....

.....

.....

.....

(iii) Use the graph to find the volume of carbon dioxide that would be collected if 10 cm<sup>3</sup> of acid were used. (1)

volume of carbon dioxide = ..... cm<sup>3</sup>

(iv) Use the graph to find the volume of sulfuric acid that would result in 55 cm<sup>3</sup> of carbon dioxide being collected. (1)

volume of sulfuric acid = ..... cm<sup>3</sup>

**(Total for Question 5 = 8 marks)**

.....

.....

.....

.....

.....

.....

.....

.....

.....

.....

.....

.....



6 In 1774, the scientist Joseph Priestley produced oxygen by heating mercury(II) oxide, (HgO). When heated, mercury(II) oxide breaks down into its elements.

(a) (i) Write a chemical equation for the breakdown of mercury(II) oxide into its elements. (1)

(ii) What name is given to this type of reaction? (1)

(b) Priestley's method of producing oxygen is no longer used because of the high toxicity of mercury and mercury compounds.

A student prepares oxygen by adding hydrogen peroxide solution to solid manganese(IV) oxide.

The diagram shows the apparatus used.

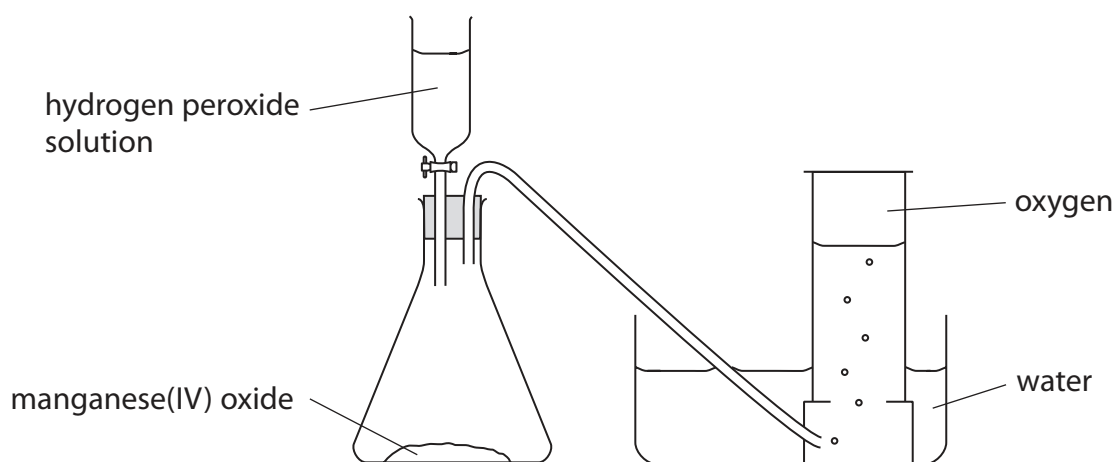

The equation for the reaction is

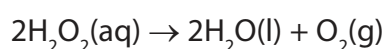

(i) Give the name of the apparatus that contains the hydrogen peroxide solution. (1)

(ii) Suggest how the first sample of gas collected may be different from the samples collected later. (1)



(c) A catalyst increases the rate of decomposition of the hydrogen peroxide.

Describe a method you could use to show that the manganese(IV) oxide is acting as a catalyst in this reaction.

(4)

.....

.....

.....

.....

.....

.....

.....

.....

.....

.....

.....

.....

.....

.....

.....

.....

.....

.....

.....

.....

.....

.....

.....

(d) Sulfur burns in oxygen to produce sulfur dioxide (SO<sub>2</sub>).

Sulfur dioxide is very soluble in water.

(i) Write a chemical equation for the reaction that takes place when sulfur dioxide dissolves in water.

(1)

.....

(ii) Universal indicator is added to the solution formed in (d)(i).

Explain the effect that the solution has on the universal indicator.

(2)

.....

.....

.....

.....

.....

.....

.....

.....

.....

.....

**(Total for Question 6 = 11 marks)**



7 Zinc is added to dilute hydrochloric acid. The equation for the reaction is

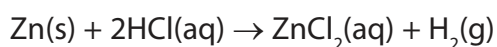

An experiment is carried out using

- 0.12 g of powdered zinc
- an excess of 0.2 mol/dm<sup>3</sup> hydrochloric acid
- a temperature of 20 °C

The volume of hydrogen collected in the experiment is measured at regular time intervals.

Curve B shows the results obtained.

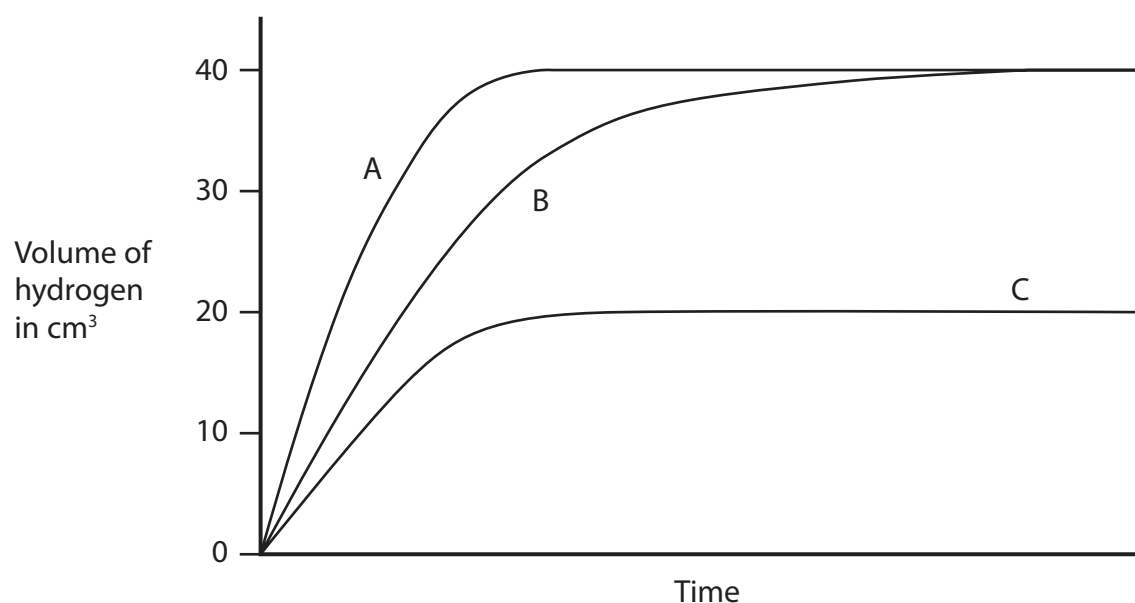

(a) The experiment is repeated using

- 0.12 g of powdered zinc
- an excess of 0.2 mol/dm<sup>3</sup> hydrochloric acid
- a temperature of 40 °C

Explain which curve, A, B or C, shows the results obtained.

(3)

.....

.....

.....

.....

.....

.....



DO NOT WRITE IN THIS AREA

DO NOT WRITE IN THIS AREA

DO NOT WRITE IN THIS AREA

DO NOT WRITE IN THIS AREA

DO NOT WRITE IN THIS AREA

DO NOT WRITE IN THIS AREA

(b) The experiment is repeated again, using

- 0.06 g of powdered zinc
- an excess of 0.2 mol/dm<sup>3</sup> hydrochloric acid
- a temperature of 20 °C

Explain which curve, A, B or C, shows the results obtained.

(3)

.....

.....

.....

.....

.....

.....

.....

**(Total for Question 7 = 6 marks)**

DO NOT WRITE IN THIS AREA

DO NOT WRITE IN THIS AREA

DO NOT WRITE IN THIS AREA

DO NOT WRITE IN THIS AREA

DO NOT WRITE IN THIS AREA

DO NOT WRITE IN THIS AREA





8 Three aqueous solutions are sodium chloride, sodium iodide and silver nitrate. They are in containers labelled X, Y and Z. It is not known which solution is in each container.

The solutions are mixed together as shown in the table, and the observations recorded.

Experiment	Observation
solution X added to solution Y	yellow precipitate formed
solution X added to solution Z	no change
solution Y added to solution Z	white precipitate formed

(a) Explain how the results show that Y is aqueous silver nitrate.

(1)

.....

.....

(b) Explain how the results can be used to identify both X and Z.

(2)

.....

.....

.....

(c) Aqueous chlorine is added to separate aqueous solutions of sodium chloride and sodium iodide.

Explain how the observations made can be used to distinguish between sodium chloride and sodium iodide.

(2)

.....

.....

.....

**(Total for Question 8 = 5 marks)**

DO NOT WRITE IN THIS AREA

DO NOT WRITE IN THIS AREA

DO NOT WRITE IN THIS AREA

DO NOT WRITE IN THIS AREA

DO NOT WRITE IN THIS AREA

DO NOT WRITE IN THIS AREA



9 Iron is extracted from its ore using a blast furnace.

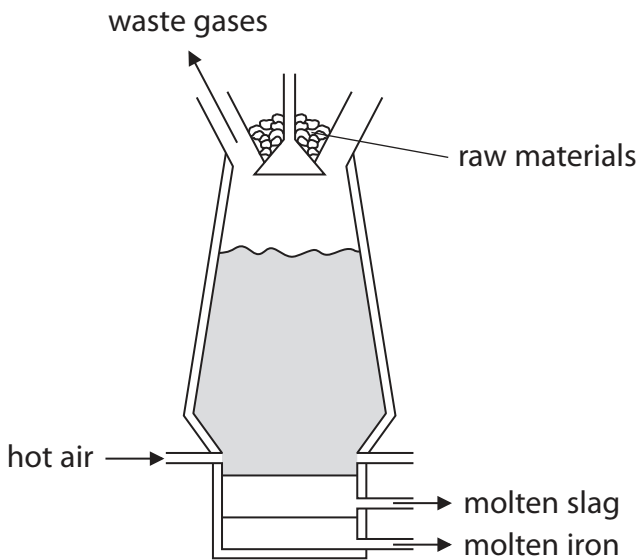

(a) The iron ore is mixed with two other raw materials and put into the top of the furnace.  
Give the names of the two other raw materials.

(2)

- 1 .....
- 2 .....

(b) The most common ore used is haematite, which contains iron(III) oxide,  $\text{Fe}_2\text{O}_3$   
The oxide is converted into iron by reaction with carbon monoxide, CO

(i) Write a chemical equation for the reaction between iron(III) oxide and carbon monoxide.

(2)

(ii) Explain which element is reduced in this reaction.

(2)

- .....
- .....
- .....
- .....



(c) The iron from the blast furnace contains about 10% by mass of impurities.

Two of the impurities are carbon and silicon.

The diagram shows a method of decreasing the amounts of carbon and silicon in the iron.

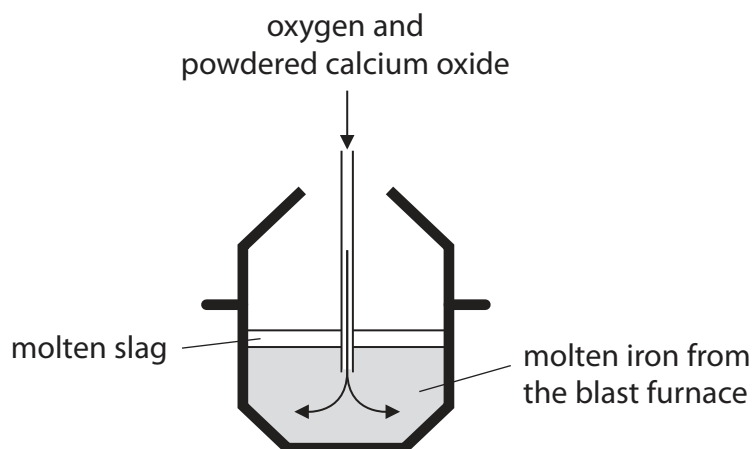

The oxygen converts carbon and silicon into their oxides.

The carbon dioxide escapes as a gas. Silicon dioxide reacts with the calcium oxide to form molten slag.

(i) Write a chemical equation for the reaction between carbon and oxygen to form carbon dioxide.

(1)

(ii) The equation for the reaction between silicon dioxide and calcium oxide to form slag is

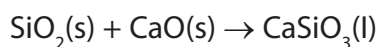

What type of reaction is this?

(1)

- A combustion
- B decomposition
- C neutralisation
- D redox



(d) One problem with using iron is rusting.

(i) Name the two substances that must be present for iron to rust. (2)

1 .....  
2 .....

(ii) One method of preventing iron from rusting is to paint it.  
State how this method of rust prevention works. (1)

.....  
.....

(e) Iron can also be protected from rusting by coating it with zinc.

(i) Give the name of this type of protection. (1)

.....

(ii) Explain how this method of protection works, even when the surface of the zinc is scratched to expose the iron underneath. (2)

.....  
.....  
.....

(f) Aluminium is extracted from its oxide using electrolysis.

(i) Why is aluminium **not** extracted by heating its oxide with carbon monoxide? (1)

.....  
.....

(ii) Why is iron **not** extracted from its oxide using electrolysis? (1)

.....  
.....

(Total for Question 9 = 16 marks)

DO NOT WRITE IN THIS AREA

DO NOT WRITE IN THIS AREA

DO NOT WRITE IN THIS AREA

DO NOT WRITE IN THIS AREA

DO NOT WRITE IN THIS AREA

DO NOT WRITE IN THIS AREA



10 Alkenes are unsaturated hydrocarbons.

(a) State what is meant by the term **unsaturated**.

(1)

.....

.....

(b) One method of producing alkenes is by cracking alkanes.

(i) Complete the equation for the cracking of decane into octane ( $C_8H_{18}$ ) and ethene.

(1)



(ii) State two conditions used for cracking alkanes in industry.

(2)

.....

.....

.....

(c) The diagram shows two alkenes that are isomers of each other.



(i) Explain why these two compounds are isomers.

(2)

.....

.....

.....

DO NOT WRITE IN THIS AREA

DO NOT WRITE IN THIS AREA

DO NOT WRITE IN THIS AREA

DO NOT WRITE IN THIS AREA

DO NOT WRITE IN THIS AREA

DO NOT WRITE IN THIS AREA



(ii) Draw a diagram to show the structure of an alkene that is another isomer of these two compounds.

(1)

(d) The structure of propene is

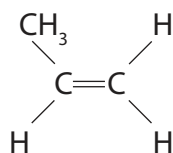

Propene can be polymerised.

(i) Give the name of the polymer formed from propene.

(1)

(ii) Draw the repeat unit for this polymer.

(2)

(e) The repeat unit of an addition polymer used in a type of glue is shown in the diagram.

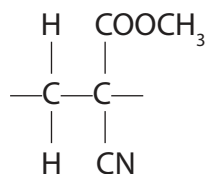

Draw the structure of the monomer used to make this polymer.

(1)

(Total for Question 10 = 11 marks)



P 4 6 8 1 4 A 0 2 1 3 2

- 11 The apparatus shown in the diagram can be used to investigate the colours of the cobalt(II) ion ( $\text{Co}^{2+}$ ) and the chromate ion ( $\text{CrO}_4^{2-}$ ) in cobalt(II) chromate.

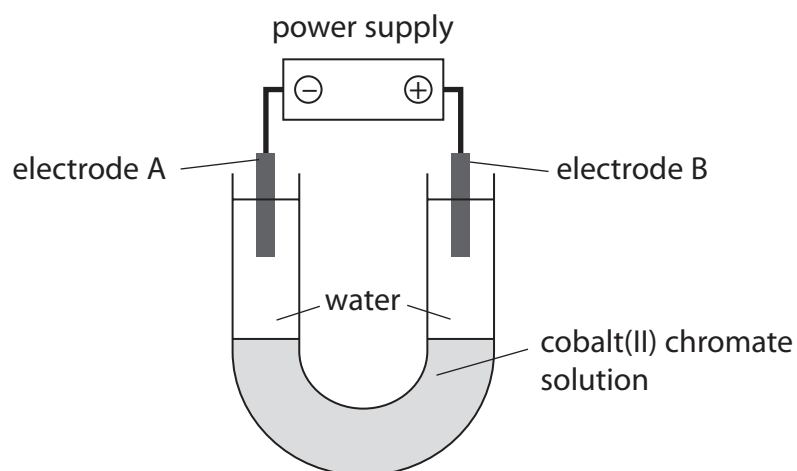

These are the results of the experiment.

- a pink colour moves towards electrode A
- a yellow colour moves towards electrode B

(a) Explain how the results show that the chromate ion is yellow.

(2)

.....

.....

.....

(b) (i) Chromate ions in aqueous solution can be converted into dichromate ions ( $\text{Cr}_2\text{O}_7^{2-}$ ) by the addition of hydrogen ions.

Balance the equation that represents this reaction.

(1)

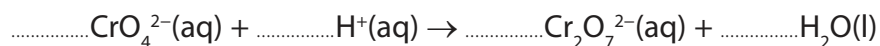

(ii) Which solution is a source of hydrogen ions for this reaction?

(1)

- A  $\text{H}_2\text{O}_2(\text{aq})$
- B  $\text{HCl}(\text{aq})$
- C  $\text{NaOH}(\text{aq})$
- D  $\text{NH}_3(\text{aq})$



DO NOT WRITE IN THIS AREA

DO NOT WRITE IN THIS AREA

DO NOT WRITE IN THIS AREA

DO NOT WRITE IN THIS AREA

DO NOT WRITE IN THIS AREA

DO NOT WRITE IN THIS AREA



(c) When aqueous potassium chromate is added to aqueous lead(II) nitrate, a bright yellow precipitate is formed.

(i) Complete the equation for the reaction by inserting the missing state symbols.

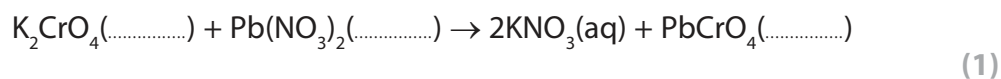

(ii) Describe how you could obtain a pure, dry sample of the insoluble solid from the final reaction mixture.

(3)

.....

.....

.....

.....

.....

.....

.....

**(Total for Question 11 = 8 marks)**

DO NOT WRITE IN THIS AREA

DO NOT WRITE IN THIS AREA

DO NOT WRITE IN THIS AREA

DO NOT WRITE IN THIS AREA

DO NOT WRITE IN THIS AREA

DO NOT WRITE IN THIS AREA



12 A student uses this apparatus to determine the volume of one mole of carbon dioxide gas.

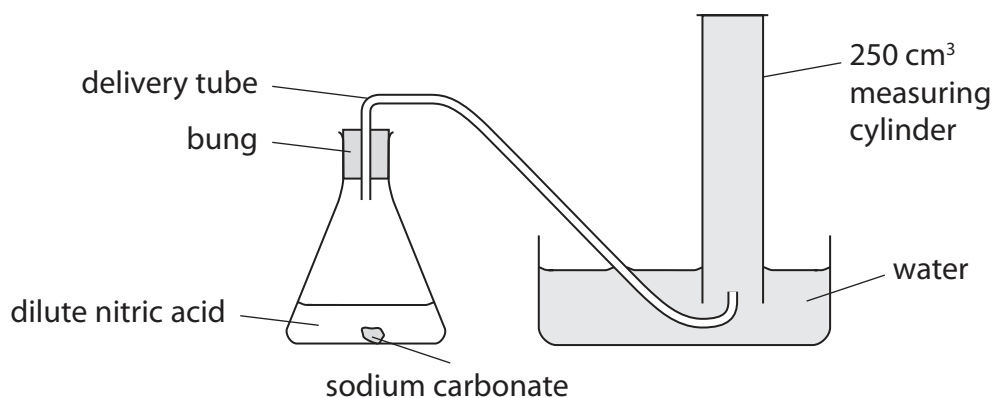

This is the student's method.

- a solid lump of sodium carbonate of mass 0.53 g is placed into the conical flask
- an excess of dilute nitric acid is added and the bung is put in place
- when all of the sodium carbonate has reacted, the volume of carbon dioxide collected is measured

The equation for the reaction is

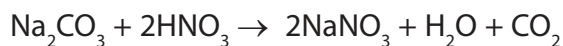

- (a) (i) Calculate the amount, in moles, of sodium carbonate that reacts.  
 [ $M_r$ :  $\text{Na}_2\text{CO}_3 = 106$ ]

(2)

amount of sodium carbonate = ..... mol

- (ii) The volume of carbon dioxide collected is 110 cm<sup>3</sup>.

Use this information and your answer to (a)(i) to calculate the volume, in cm<sup>3</sup>, of one mole of carbon dioxide.

(2)

volume of one mole of carbon dioxide = ..... cm<sup>3</sup>

DO NOT WRITE IN THIS AREA

DO NOT WRITE IN THIS AREA

DO NOT WRITE IN THIS AREA

DO NOT WRITE IN THIS AREA

DO NOT WRITE IN THIS AREA

DO NOT WRITE IN THIS AREA



(b) The correct value for the volume of one mole of carbon dioxide, under the conditions used in the experiment, is 24 000 cm<sup>3</sup>.

Suggest two reasons why the volume calculated from the experiment is less than the correct value.

(2)

1 .....

.....

.....

2 .....

.....

.....

**(Total for Question 12 = 6 marks)**

DO NOT WRITE IN THIS AREA

DO NOT WRITE IN THIS AREA

DO NOT WRITE IN THIS AREA

DO NOT WRITE IN THIS AREA

DO NOT WRITE IN THIS AREA

DO NOT WRITE IN THIS AREA



13 This question is about different metals.

The list shows part of the reactivity series of metals.

potassium	most reactive
sodium	↑
magnesium	↑
zinc	↑
iron	↑
lead	↑
copper	least reactive

(a) Name a metal from the list that is extracted by electrolysis.

(1)

(b) Uranium is a metal that is in between magnesium and zinc in the reactivity series.

Equal sized pieces of these three metals are placed in separate solutions of dilute hydrochloric acid of the same concentration and at the same temperature.

The observations for magnesium and zinc are shown in the table.

Complete the table by stating the observations that would be made for uranium.

(2)

Metal	Observations
magnesium	Bubbles of gas produced very rapidly. Solid disappears very quickly.
zinc	Bubbles of gas produced slowly. Solid disappears slowly.
uranium	

(c) (i) Metals high in the reactivity series react readily with water.

Name the compound formed when potassium reacts with water.

(1)

(ii) Give the formula of the compound formed when magnesium reacts with steam.

(1)



(d) Zinc can be extracted by heating zinc oxide with carbon.

The equation for the reaction is

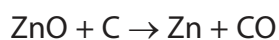

(i) Explain whether zinc or carbon is the more reactive element.

(1)

.....

.....

.....

(ii) Explain which element is acting as a reducing agent in this reaction.

(2)

.....

.....

.....

.....

**(Total for Question 13 = 8 marks)**

DO NOT WRITE IN THIS AREA

DO NOT WRITE IN THIS AREA

DO NOT WRITE IN THIS AREA

DO NOT WRITE IN THIS AREA

DO NOT WRITE IN THIS AREA

DO NOT WRITE IN THIS AREA



14 Nitrogen dioxide (NO<sub>2</sub>) and dinitrogen tetroxide (N<sub>2</sub>O<sub>4</sub>) exist together in equilibrium.

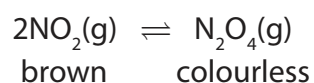

- (a) The gas syringe contains a sample of an equilibrium mixture of the two gases. The mixture is brown in colour.

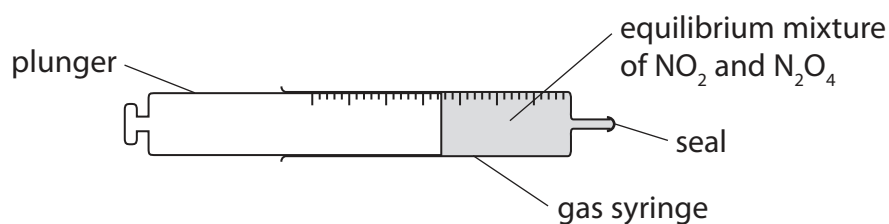

The plunger is pulled out to reduce the pressure of the gaseous mixture. When the equilibrium is reached the mixture is darker in colour.

Explain this observation.

(3)

.....

.....

.....

.....

.....

.....

DO NOT WRITE IN THIS AREA

DO NOT WRITE IN THIS AREA

DO NOT WRITE IN THIS AREA

DO NOT WRITE IN THIS AREA

DO NOT WRITE IN THIS AREA

DO NOT WRITE IN THIS AREA



(b) (i) A sealed tube containing an equilibrium mixture of  $\text{NO}_2$  and  $\text{N}_2\text{O}_4$  at room temperature is plunged into water at  $0^\circ\text{C}$ . The colour of the mixture changes from brown to pale yellow.

Explain whether the forward reaction is exothermic or endothermic.

(2)

.....

.....

.....

.....

(ii) In the forward reaction, a bond is formed between the two nitrogen dioxide molecules.

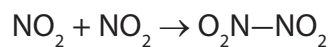

Explain whether this information supports your answer in (b)(i).

(1)

.....

.....

.....

**(Total for Question 14 = 6 marks)**

DO NOT WRITE IN THIS AREA

DO NOT WRITE IN THIS AREA

DO NOT WRITE IN THIS AREA

DO NOT WRITE IN THIS AREA

DO NOT WRITE IN THIS AREA

DO NOT WRITE IN THIS AREA



P 4 6 8 1 4 A 0 2 9 3 2



15 Lithium and magnesium both react with nitrogen.

The chemical equation for the reaction between lithium and nitrogen is

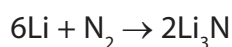

(a) Write the chemical equation for the reaction between magnesium and nitrogen.

(2)

(b) The equation for the reaction between lithium nitride and water is

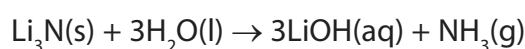

(i) Describe a chemical test to show that the gas given off is ammonia.

(2)

(ii) A sample of 1.40 g of lithium nitride is added to an excess of water.

Calculate the amount, in moles, of  $\text{Li}_3\text{N}$  in the sample of lithium nitride.

(2)

amount of  $\text{Li}_3\text{N}$  = ..... mol

(iii) Calculate the amount, in moles, of  $\text{LiOH}$  in the lithium hydroxide formed.

(1)

amount of  $\text{LiOH}$  = ..... mol

DO NOT WRITE IN THIS AREA

DO NOT WRITE IN THIS AREA

DO NOT WRITE IN THIS AREA

DO NOT WRITE IN THIS AREA

DO NOT WRITE IN THIS AREA

DO NOT WRITE IN THIS AREA



(iv) Calculate the volume of 0.500 mol/dm<sup>3</sup> sulfuric acid required to neutralise exactly the amount of lithium hydroxide calculated in (b)(ii).

Give an appropriate unit.

The equation for the reaction is

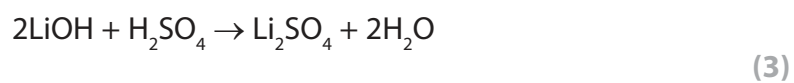

volume of sulfuric acid = ..... unit .....

**(Total for Question 15 = 10 marks)**

**TOTAL FOR PAPER = 120 MARKS**



DO NOT WRITE IN THIS AREA

DO NOT WRITE IN THIS AREA

DO NOT WRITE IN THIS AREA

**BLANK PAGE**

Every effort has been made to contact copyright holders to obtain their permission for the use of copyright material. Pearson Education Ltd. will, if notified, be happy to rectify any errors or omissions and include any such rectifications in future editions.

